

**MIE**  
and  
my  
Identity

**MisuraEmme®**

# EVERYTHING BEGAN IN 1902

THE FIRST PRODUCTION OF HANDCRAFT FURNITURE

Since 1902 four generations of entrepreneurs have focused on a cutting-edge production, where the engineering and care for details has always been followed at every stage.

A constant attention to the development of innovative and often revolutionary projects, a natural capability to new housing trends; a great concern to the quality of the materials used: this is what makes the difference.

Today MisuraEmme is the result of a heritage built over time, by consolidating know-how and strong values, to offer the market products that synthesize the best of "Made in Italy" and are in line with today's environmental requirements. Furthermore, MisuraEmme is also able to support constructors and designers, assisting them in their various professional needs.



1939

PRESENCE TO THE FIRST TRADE  
EXHIBITIONS BEFORE **SALONE DEL MOBILE**



1945 - 1955

AFTER THE WAR - G.L. F.LLI MASCHERONI



## LOGOTYPE

1960 - THE FIRST LOGOTYPE  
1970 - THE ACTUAL LOGOTYPE  
1996 - ATELIER®



**MisuraEmme**

**atelier**

## 1961

CO-FOUNDER OF **SALONE DEL MOBILE EXHIBITIONS**



# DOING BUSINESS WITHOUT POLLUTING

GRANDESIGNETICO® INTERNATIONAL AWARD

MisuraEmme Spa was rewarded for this new product, versatile, exible, easy to inspect and eco-friendly for the attention to the environment which distinguish the policy of the company and that is evident in the many aspects of the products also particularly careful to the clean lines of the design. In particular for the realization of painted products totally water-based. The company demonstrates its continued commitment to the environmental protection and health of customers and re-launches its history of strong brand, born in 1902 and still in the hands of the same family group, authentic witness of Italian know-how in the world.

MisuraEmme is the first company in the furniture sector in Italy to have installed a painting plant with low environmental impact with MOS technology TM, taking advantage of products completely water based. Every year in Italy are emitting a million and a half tons of volatile organic compounds. polluting solvents for a third party derived from wood painting, responsible for many diseases.

MisuraEmme turns its extensive range of products with a high-end customers, knowledgeable and informed. In line with the evolution of social awareness of their target audience, MisuraEmme has decided to take effective action to promote the collective welfare, especially in contract projects for hotels around the world.



# PRODUCTION SITE

GOOGLE® IMAGE OF MISURAEMME® PRODUCTION SITE



# MARKET OVERVIEW

OVER 40 COUNTRIES  
ITALY \_ 250 STORES  
FOREIGN \_ 236 STORES - 180 EUROPE AND 56 OVERSEAS

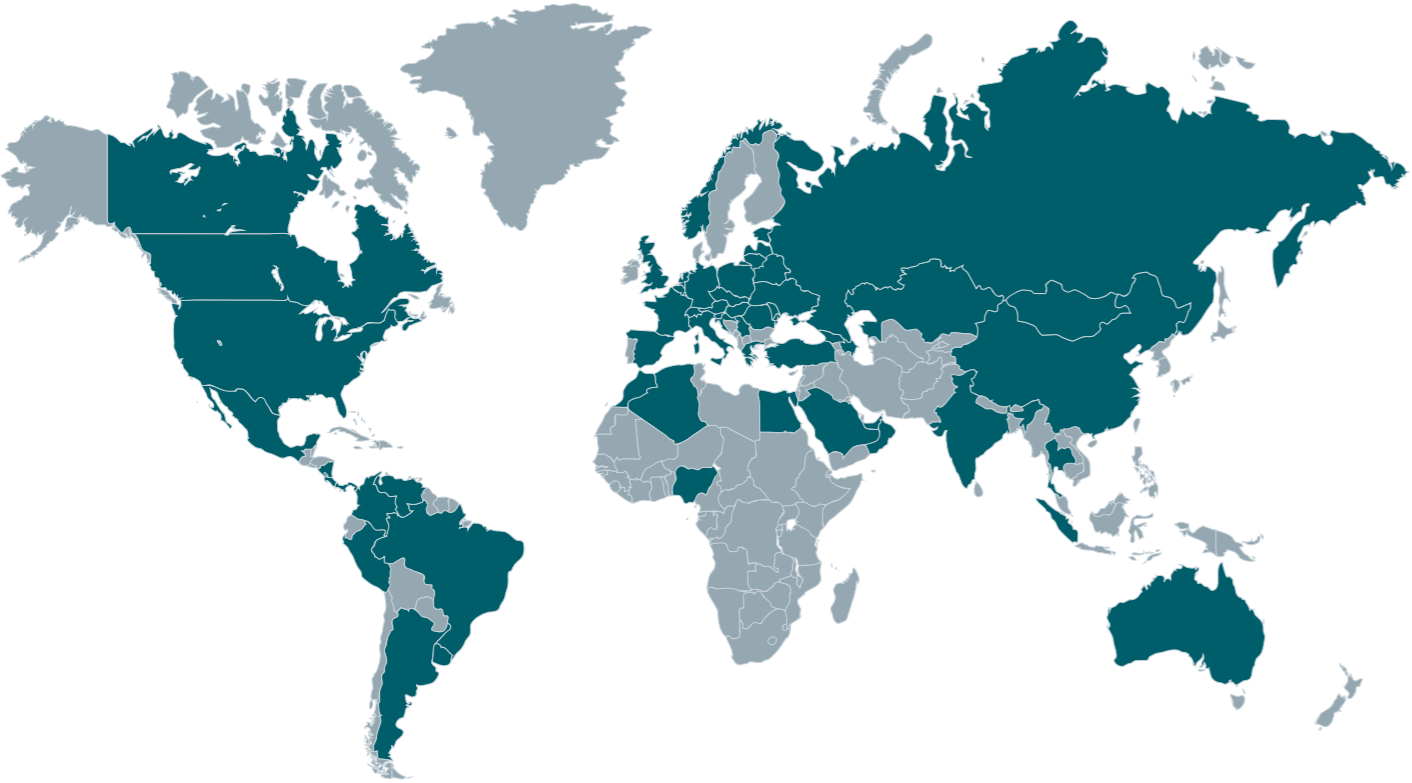

# MARKET OVERVIEW

ITALY \_ 20 %  
REST OF THE WORLD \_ 80 %



# PRODUCT SEGMENT

DAY \_ 35 %  
NIGHT \_ 65 %

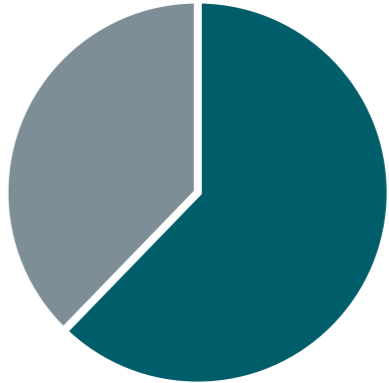

## A TIMELESS STORY

The history of MisuraEmme started in the early years of the last century by Giovanni the father of Giuseppe and Luigi Mascheroni, who in 1902 founded the base of the company in Mariano Comense in the heart of the prolific district of furniture Brianza, well known for its excellent manufacturing. Today the establishment has a surface of 35.000 mq.

***Passed on by three generations, the know-how of MisuraEmme is the result of consolidated knowledge over time and loyalty to strong and imperative values.***

***100% made in Italy, designed by famous architects and realised making use of the artisan culture of professionals of the Brianza area.***

The products of MisuraEmme embody the wish to combine tradition with innovation. Today the company is not only capable of proposing furniture characterised by a high level of personalisations and one-on-one designs with the client, but also to export these values, designing solutions in tune with different international requirements.





## EYE-CATCHING DETAILS

The attention to details is imperative at MisuraEmme. That's clear not only from the choice of materials of excellent quality - from Carrara marble in solid oak, through the Made in Italy fabrics or leathers from Europe - but also by the use of special processing and craftsmanship that give an added value the complements. All this and much more makes the products of MisuraEmme unique and exclusive result of the wonderful blend of formal refinement and technological innovation.

***This and much more makes MisuraEmme products unique and exclusive, a wonderful blend of formal refinement and technological innovation.***

***When chromatic harmony and refinement join together, home gets back to a refined treatment.***



# THERE IS A NEW TECHNOLOGY THAT DOES NOT POLLUTE

*For MisuraEmme productivity and respect for the environment are inseparable.  
Because of intense efforts both in time and resources,  
the company now disposes of a revolutionary water-soluble based lacquer system,  
for which it was awarded with the first prestigious mark Acquaver® and also  
in 2014 the "grandesignEtico" international Awards.*

*Thanks to this innovative system, the matt lacquer finishes of MisuraEmme are  
environmentally friendly and non-toxic, values to be spent by hotels to attract  
people particularly sensitive to pollution problems.*





## HIDDEN QUALITIES

*Hotel furnitures are subjected to an heavy-duty use, so we need to provide solutions and products studied to be long-lasting and which can with stand daily customer use.*

***The products of MisuraEmme distinguish themselves not only through their high aesthetic value but also for the high quality of projecting and engineering.***

*Crossing system, with three crossing layers of poplar blockboard, the hanging frame with cable-passage fortting TV panels and hanging units to the wall (wiht roll over protection system) or the back panels placed between containers, that allow the passing of cables at any height, are only some of the hidden and hightly innovative qualities designed by MisuraEmme to adapt to modern technologies.*

# MASTER DESIGNERS

## ICONIC PIECES

Legendary, iconic, praiseworthy pieces synonymous with timeless style and some of the most important moments in the history of design. Our evergreen traditions have been immortalised by the hand of the great masters and enhanced by some of the most creative minds around, finding the perfect home at MisuraEmme.

# 1931 WERNER MAX MOSER

ARMACHAIR **WM1**

Werner Max Moser, born in 1896 in Karlsruhe (D), studied architecture both in Zürich with his father Karl Moser and at Stuttgart with Bonatz, Abel and Fiechter. He worked with different architects in Holland and in the USA, where he spent two years at Frank Lloyd Wright's atelier. He carried out important projects in Switzerland and Germany, such as the Budge-Heim house in Frankfurt and the Neubühl Siedlung in Zürich, constructed with the collaboration of Mart Stam and Ferdinand Kramer. After lecturing at Harvard University, he became professor at the Polytechnic High School of Zürich. In 1931 Moser, along with Siegfried Giedon and Rudolf Graber, founded the Wohnbedarf AG Zurich—the collection for which he designed numerous models.





## 1932 ALFRED ROTH

### BAR TROLLEY AR1

Alfred Roth was born in Wangen (Switzerland) on 21 May 1903. He took a degree in Zurich with Karl Moser and began working in the studio of Le Corbusier and Pierre Jeanneret, creating two houses for the International Exhibition in Stuttgart. In 1931 he opened his own architecture office in Zurich, and carried out important projects in Switzerland, Sweden, the United States, and the Middle East. In collaboration with Marcel Breuer he designed the Doldertal houses in Zürich. In addition to serving as a visiting professor at the Universities of Harvard and Saint Louis, as well as at the Zurich Polytechnic, he published various books on architecture and his contacts with Le Corbusier, Loos, Hoffman, Perret, Van de Velde and Piet Mondrian.

# 1949 IGNAZIO GARDELLA

## BOOKCASE ELEGIE

The descendent of a family of engineers and architects – a tradition that he respected, graduating in Civil Engineering from the Politecnico di Milano in 1928 –, Ignazio Mario Gardella, born in 1905 and deceased in 1999, played a central role in all the new developments of the 20th century, becoming one of the architects of the changes underway in the world of design and architecture. His numerous trips abroad, the connections he made during his university years and the work that came from his father's firm put him into contact with a series of prominent figures of the time who left a deep mark on his architectural approach, a precious legacy for the modern day that fused methodical precision and intellectual curiosity.

It was mainly the city of Milan that benefitted from his eclectic and disruptive personality, ever since Gardella became one of the promoters of the Piano A.R. ("Architects Reunited Plan") in 1943: this project for a new city plan constituted one of the greatest tests for Milanese architects due to its optimistic desire to rethink and rebuild the city as an expression of a new democratic society. With this in mind, in 1945 he became one of the founders of the Movimento di Studi per l'Architettura (MSA – Movement for Architectural Studies), committing himself to tackling the main issues of the architectural and city planning debate regarding reconstruction. His conception of architecture as "art", somewhere between a utilitarian construction and an artistic work, inevitably influenced the products that resulted from his collaboration with MisuraEmme, which began in the '70s. Gardella redesigned historic pieces and created a new collection, marking an important moment in the company's history.





## 1984 WOLFGANG LAUBERSHEIMER

TENSOBOOKCASE WL2

Wolfgang Laubsheimer, born in Bad Kreuznach (D) in 1955, is one of the founders of the "Pentagon" group which had a great success on the exhibition "Documenta 8" at Kassel. Furniture of simple forms using durable materials which contrast on one side with the "Gute Form" of postwar Bauhaus traditions and on the other the post-modern tendencies of the 80's. The intention of these young german designers beig, to create independent projects which radically change the traditional concept of living.

# HISTORY PRODUCTS

MISURAEEMME®

A precious material that is reminiscent of tradition and evokes emotions. An added value that highlights a handcrafted construction and enhances a timeless elegance that transcends fashion trends.



1934  
GIUSEPPE TERRAGNI

TABLE AND CHAIRS GT1-GT2-GT3





1979  
UGO LA PIETRA

PLAYTABLE AND SMALL ARMCHAIR **MESSINSCENA**

1981  
SERGIO ASTI

TABLE MANDARIN





1984  
DANTE BENINI

NIGHT GROUP GIUDECCA

1986  
ALBERTO DAL LAGO

BOOKCASE JOKER





1988  
ENNIO AROSIO

BED BEATRICE

1993  
ENNIO AROSIO

BED CAMILLA





1996  
JACQUES TOUSSAINT

CHAIRS JT1-JT2



1998  
C. MARELLI & M. MOLteni

BED VITTORIA



# CONTEMPORARY PRODUCTS

MISURAEEMME®

Precision, purity, contemporary design and functionality. A perfect combination that gives rise to a new contemporary lifestyle aesthetic that lends remarkable harmony to living environments. Linear geometry and sculptural volumes modulate space that has become self-defining, a stage on which high quality, innovation and attention to detail represent glamor and timeless charm.

2001  
MAURO LIPPARINI

BED TAO





## 2002 MAURO LIPPARINI

### SOFA **BORDERLINE**

Inspired and original yet still in line with that quintessential sense of bespoke comfort, **Borderline** helps to bring a feel of intimacy to the contemporary home. The sleek, lightweight design elongates at the armrests, which are supported by stunning brackets in satined metal, boosting the levity of the piece.

# 2008 MARCO PIVA

## ARMCHAIR **SURFACE**

The refined elegance of **Surface** is a result of its sinuous design. The combination of colors and different materials defines the boundary between inside and outside, creating a comfortable, soft nest.





## 2010 LUCA SCACCHETTI

CHEST OF DRAWERS **PROSCENIO**

Skilful craftsmanship of wood and the characteristic handle, make **Proscenio** a very unique design product.

# 2011 FERRUCCIO LAVIANI

## TABLE ALA

A combination of creativity and expert craftsmanship, the **Ala** table is the dominant presence in the living room – the setting for the day-to-day goings-on of domestic life. The round or semi-oval table top, outlined by a border that takes the edge off the thickness, appears suspended in mid-air, almost ready to take flight. The tapered legs only heighten this effect, based on the design of the wings of an aeroplane.





## 2011 FERRUCCIO LAVIANI

### SOFA **CANNES**

The **Cannes** sofa is more like a collection of different elements that can be connected up to create a whole. These freestanding parts can be mixed and matched to suit each owner's taste, ensuring no two solutions are ever the same. Style and practicality are the watchwords of this contemporary sofa.



# 2012 MAURO LIPPARINI

ARMCHAIR **ERMES**

A reinterpretation of the wraparound design of the **Ermes** chair with the use of special color and material choices. The usual craftsmanship for every little detail highlights the unusual combinations, emphasizing the aesthetic qualities of the product. Full shapes create an intimate dimension, an invitation to relax.

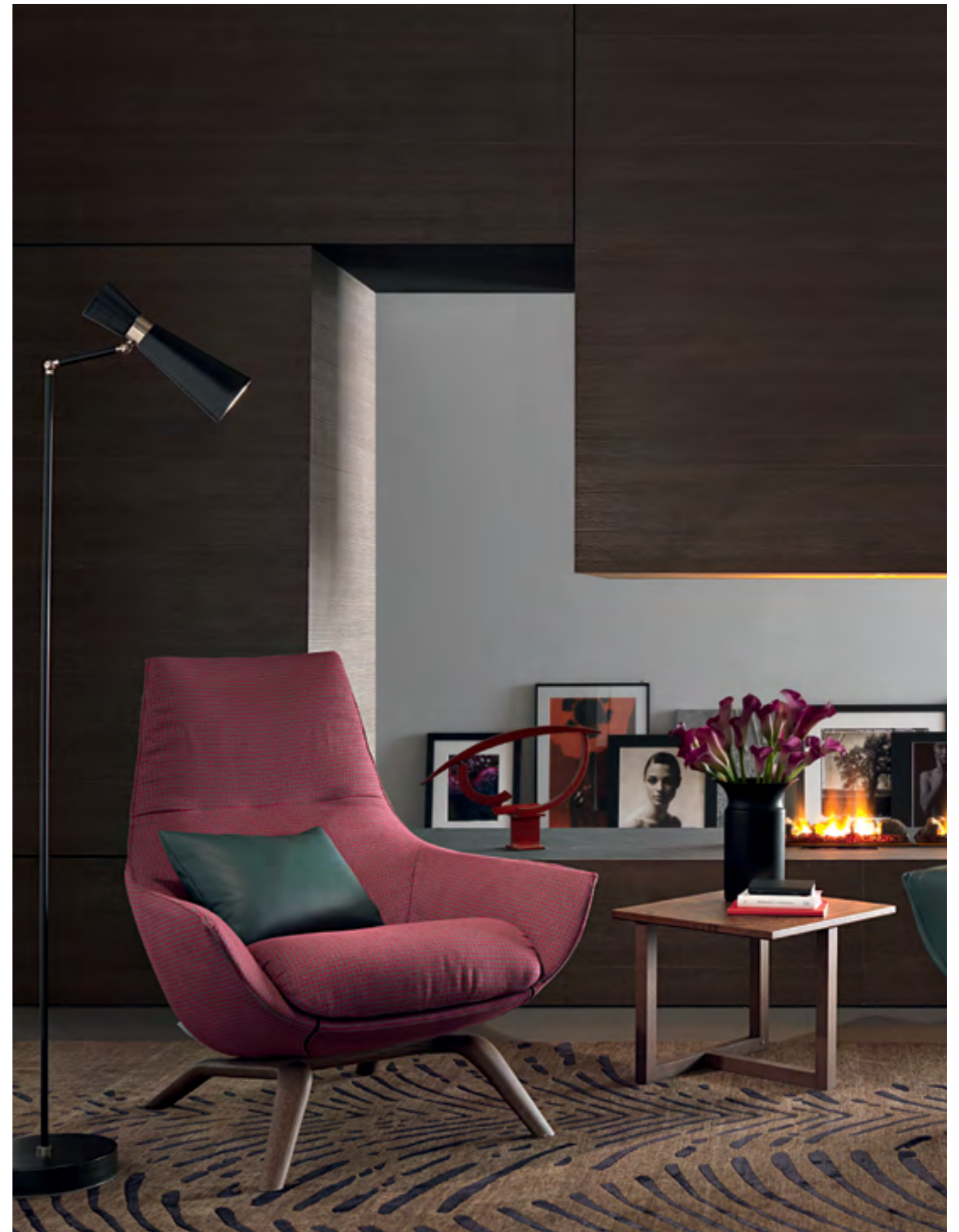



## 2012 FERRUCCIO LAVIANI

### TABLE GAUDÌ

Stunning materials and practical design come together for timeless style. **Gaudi** packs an unexpected punch thanks to its tapered semi-oval top, embellished with either gorgeous natural stone, marble or wood, depending on individual furnishing needs.

# 2013 C. MARELLI & M. MOLteni

## BED MARGARETH

**Margareth** bed is a well balance mix of elegance and exclusivity, with its light and ethereal design, combined with the most advanced technology materials. The steel head board, covered in fabric seamed on the edges with a sophisticated tailored handcrafted detail, creates a seductive looking. The base in solid wood is upholstered as well with matching fabric and enhances the design of the solid wood foot shape that supports the bed.





## 2013 MAURO LIPPARDINI

### TABLE GRAMERCY

**Gramercy** is a delicate object with a gentle silhouette, designed to bring taste and modernity to the living area. The tapered semi-oval top rests on an elegant, simple structure in solid oak with artisanal finishes. The whole piece is an exercise in balance between levity and solidity – the former is provided by unassuming, sleek legs, the latter by the central join that ensures stability for the structure.

2014  
MAURO LIPPARINI

SMALL TABLE **GRAMERCY**

Harmonious design and soft lines with clear influence drawn from the world of sculpture, coming together to create a piece with absolute aesthetic value. Different dimensions and materials make for a sophisticated item for the living room. The legs, a triptych easel, follow the same drawing of **Gramercy** table.





## 2017 MAURO LIPPARINI

### ARMCHAIR VIOLETTA

**Violetta** features a gentle, flowing design, paired with a swivel base in gunmetal grey. This armchair will bring personality to any lounge thanks to the huge number of upholstery options available in fabric, leather or eco-leather.

# 2017 MAURO LIPPARINI

## SOFA PHOENIX

**Phoenix** conquers the living room with its winning mix of ethereal elegance, rigour and purity, contemporary design and functionality. The new sofa system may be based around simple lines, but it offers a raft of compositional possibilities. Available in a fixed or modular version, the latter encompassing a dormeuse, pouffe and chaise longue, its cosy design ensures the perfect setting for some serious relaxation.





## 2018 CR&S MISURAEEMME®

SMALL TABLE RIALTO

This sleek and shiny table in nickel-plated metal with a gold finish is supported by three tubular legs arranged in a triangle and soldered together. The legs support the sunken tray, which in turn holds the marble table top, bringing a delicate touch to contemporary spaces.



# 2018 FRANCESCO LUCCHÈSE

## SMALL TABLE JANUS

The unique structure, characterised by the combination of two double C-shaped elements in metal, is what captures the eye first. Available in various different heights and finishes, the structure supports the table top (either round or semi-oval in shape), which can be finished in materials such as marble, wood and glass. **Janus**, it all adds up to a flowing design heightened by the use of the finest materials – all expertly handled, of course.





## 2018 FRANCESCO LUCCHESI

### SIDEBOARD **MILVIAN**

**Milvian** features some sublime and sophisticated styling, combining bold lines with the finest detailing. The flowing wood structure is framed by curved side panels, which feel pleasant to the touch and draw the gaze as they continue to the floor, where they transform gracefully into feet. There is a wonderful sense of balance to the piece, with customers able to choose the finish for the top from the large number of options in the range. Also available the version with fixed front for double-sided use.

2018  
ANDREI MUNTEANU

SMALL TABLE **ANTARES**

**Antares** sophisticated presence alone is enough to capture the attention of everybody in the room. The table is cylindrical in shape, with a sleek yet solid sheet wrapping round the structure, enveloping and protection the precious marble table top, whose distinctive, subtle veining creates a stunning visual effect.





## 2018 ANDREI MUNTEANU

### SMALL TABLE **SIRIUS**

This sleek and shiny table in nickel-plated metal with a gold finish is supported by three tubular legs arranged in a triangle and soldered together. The legs support the sunken tray, which in turn holds the marble table top, bringing a delicate touch to contemporary spaces.

# 2018 FRANCESCO LUCCHÈSE

## CHAIR BRERA

A homage to contemporaneity yet bold enough to draw inspiration from classic styles, the **Brera** chair is all unique design and strong identity. The internal structure is made from oval tubing, while the exterior is completely covered in leather. The unusual inclination of the top part of the padded backrest brings added dynamism, while also making the chair easier to grasp.





## 2019 MAURO LIPPARINI

### SOFA **VIRGIN**

Compact but comfortable, the **Virgin** sofa has essential refined lines that give the design a rigorous tone. The back and armrests merge in a single functional upholstered unit, wrapping the deep seat that becomes the rear support, altering its image and final purpose. A strategic gap between the seat and back lightens the weight of the volume.

# 2019 ANDREI MUNTEANU

## SMALL TABLE **STILETTO**

Material contrasts underline the forceful identity of the new **Stiletto** family of furnishing complements. Marble, metal and wood alternate in creations with vivid geometric effects that enhance the slender structure. Tables – in different heights and with different sizes for the tops – rise from the floor in tandem with the brand's seating, in an original game of juxtapositions with the soft silhouettes of the sofas and armchairs.





## 2019 FERRUCCIO LAVIANI

### TABLE ALA

A combination of creativity and expert craftsmanship, the **Ala** table is the dominant presence in the living room – the setting for the day-to-day goings-on of domestic life. The round or semi-oval table top, outlined by a border that takes the edge off the thickness, appears suspended in mid-air, almost ready to take flight. The tapered legs only heighten this effect, based on the design of the wings of an aeroplane.



EVOLUTION OF SYSTEM  
FOR LIVING DAY

1970  
ADAM TIHANY  
STUDIO DAL LAGO

LIVING SYSTEM CONTINUITA'





## 2002 MAURO LIPPARDINI

### LIVING SYSTEM TAO DAY

Compositional precision and attention to the finest of details define for Tao compositions. A production approach inspired by contemporary living necessities, where Made in Italy excellence is expressed through transverse project development processes capable of forging glamorous yet functional solutions: a linear design enhanced by the matching of different materials.

2004  
CR&S MISURAEEMME®

LIVING SYSTEM EVOLUTION





2006  
MAURO LIPPARINI

LIVING SYSTEM MONOS

# 2008 MAURO LIPPARINI

## LIVING SYSTEM **CROSSING**

Crossing is a versatile modular system of panels with which to create wall-mounted shelving. Totally adjustable along the three dimensional axes, it can support up to 400 kg. The program offers a series of modules of different types and sizes, hanging cabinets with flap, leaf or sliding doors, and drawers in a range of sizes.

Crossing is available in the Fusion version (with parts in faced or lacquered wood particle board) or in the Listellare version (veneered or laminated poplar blockboard). The compartments contain a special LED lighting system. Finishes: matte lacquer, glossy colours, natural wood, veneer/facing.





## 2010 MAURO LIPPARINI

LIVING SYSTEM TA010

Compositional precision and attention to the finest of details define for Tao compositions. A production approach inspired by contemporary living necessities, where Made in Italy excellence is expressed through transverse project development processes capable of forging glamorous yet functional solutions: a linear design enhanced by the matching of different materials.



# 2012 IRIAM BETTERA

LIVING SYSTEM **URBAN**

The Urban system expands the creative possibilities starting from the choice of a freestanding or a wall-mounted composition, to the finishes range, up to the selection and placement of various featuring elements: colored metal boxes, storage units with flap door or fitted with drawer, tv panels, equipped with LED system, and glass sliding doors.





EVOLUTION OF SYSTEM  
FOR LIVING NIGHT

# 2001 ENNIO ARÓSIO

NIGHT SYSTEM **MILLIMETRICA**

All the charm of a space entirely dedicated to the wardrobe: geometries that fit in every architectural space, modularities that can be perfectly customized, and a wide range of accessories and complements.





## 2015 GIANNI BORGONOVO

NIGHT SYSTEM PALO ALTO

Sleek, clean-lined aesthetics and functionality: these are the key words for defining Palo Alto, the new complete night area project. The idea springs from a desire to pamper ourselves: elegant, refined, rigorous and flawless, it enables a complete and "transparent" view of the things we love.

## CONTRACT DIVISION

HOTEL & RESTAURANT  
RESIDENTIAL  
HEADQUARTERS & OFFICES  
RETAIL  
MARINE  
AUDITORIUM  
LIBRARIES & MUSEUMS  
AIRPORTS

## REFERENCES

Exclusive residential tower Beverly west - **LOS ANGELES CALIFORNIA**  
Luxury residence The International - **AUCKLAND NEW ZEALAND**  
Four Season San Paolo - **SAN PAOLO BRASILE**  
Hotel Michelangelo - **CARRARA ITALY**  
Hotel the market - **FIRENZE ITALY**  
Private villa - **MALIBÙ CALIFORNIA**  
Private seavilla - **MANAMA KINGDOM OF BAHRAIN**  
Boutique Hotel - **ETOILE DE POMPADOUR**  
Luxury Apartment - **MSHEIREB DOWNTOWN DOHA**  
Luxury Apartment - **LAMCO DESIGN**  
Japan Luxury Apartment - **CRESCENT KAWASAKI TOWER**  
Luxury Hotel - **KEMPINSKY ADRIATIC**  
Japan Luxury Apartment - **PIAS CODE TODOROKI**  
Japan Luxury Apartment - **HIGASHI SHIZUOKA**  
Motel - **ONE MOTEL**  
Exhibition - **MADE EXPO**  
Luxury Hotel - **CHATEAU D'OUCHY LAUSANNE**  
Hotel & Resort - **MONTECARLO BAY**  
Luxury Hotel - **CROWNE PLAZA**  
Luxury Hotel - **CITY WEST**  
Club & Restaurant - **NOIR**  
Club & Restaurant - **DORSIA**

# ETOILE DE POMPADOUR

BOUTIQUE HOTEL  
DOMAINE DE LA NOAILLE, FRANCE

Stretching over 63 hectares in the wild countryside of France, Etoile de Pompadour (EDP) is a unique sports and wellness destination, a realm of sports activities and a treat for foodies. Cavallo Hotel at Etoile de Pompadour stands out amongst the hotels in Correze and Limousin. Renowned for bespoke services, it is the perfect place to book a hotel in Arnac-Pompadour. This elegant and comfortable 5-star deluxe boutique hotel makes its home in a landmark building dating back to 1864. MisuraEmme helped complete the furnishing of loose and fixed furniture of the 28 rooms and suites providing: closets, bed bases, mattresses, headboards, desks, wood paneling, mirrors, vanities, chairs, sofas, coffee tables, side tables, cupboards, furniture minibar and parquet flooring. All products are custom made to follow the requests of the designer. MisuraEmme also dealt the installation of furniture, engaging in on-site customization of the furnishings adapted to the irregular shapes of the old restored building, with stone walls and wooden beams.











# MSHEIREB DOWNTOWN DOHA

LUXURY APARTMENT  
DOHA, QATAR

Msheireb is the world's first sustainable downtown regeneration project, that will revive the old commercial district with a new architectural language that is modern, yet inspired by traditional Qatari heritage and architecture - its proportion, simplicity, space, light, layering, ornament and response to climate. Utilising the latest in sustainable technologies, Msheireb will adhere to the highest standards in green building. The strategic objective of the Msheireb project is to reverse the pattern of development in Doha, which has tended towards isolated land use, reliance on car transportation and energy hungry structures. Msheireb Downtown Doha will become a new social and civic hub in the city centre - a place where it is enjoyable to live, work, shop, visit, and spend time with family and friends.









# LAMCO DESIGN

LUXURY APARTMENT  
DORSET, UK

The meeting between Lamco (the brand's local distributor) and the Woadden Nash Interiors studio spawned the Silencio Sandbanks project: seven residential properties on Dorset's Sandbanks beach. The understated sophistication and striking brightness of the spaces create the perfect setting for the First wardrobe, created by MisuraEmme for the bedroom. Meanwhile, the innovative finishing in bronzed reflective glass provides a stunning backdrop for the Hermes chairs with oak fumé base.











EXAMPLE OF  
CONTRACT PROJECTS

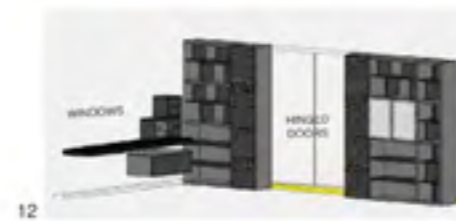
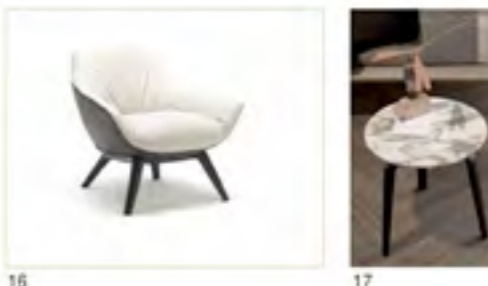

MOODBOARD



MisuraEmme  
CONTRACT

LIVING ROOM VIRGIN ARMCHAIR(4)STILETTO COFFEE TABLE(5)



MisuraEmme  
CONTRACT

LIVING ROOM GEMINI (2)AND STILETTO (3)COFFEE TABLE



MisuraEmme  
CONTRACT

OFFICE BOOKSHELVES(12)

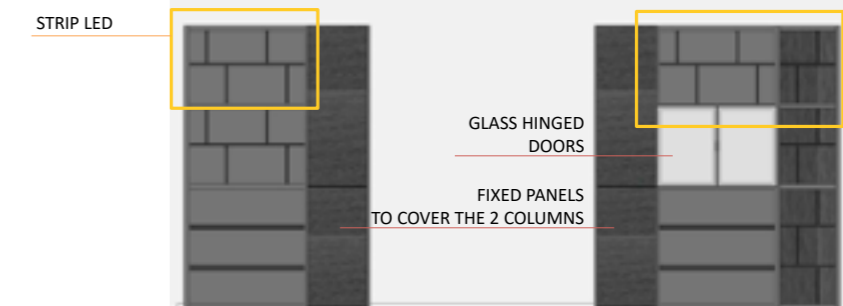
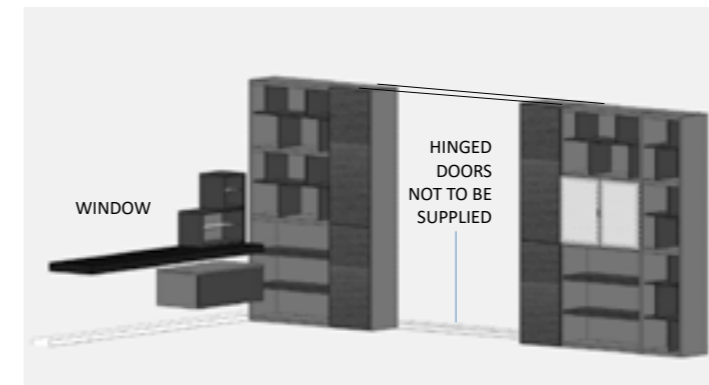

MisuraEmme  
CONTRACT

DINING ROOM GAUDI' TABLE (7) BRERA CHAIRS (8)



MisuraEmme  
CONTRACT

DINING ROOM OVER COMPOSITION (9)



MisuraEmme  
CONTRACT

OFFICE PHOENIX CHAISE LONGUE(11)



MisuraEmme  
CONTRACT

OFFICE TAO10 DESK COMPOSITION (13)



MisuraEmme  
CONTRACT

MOODBOARD

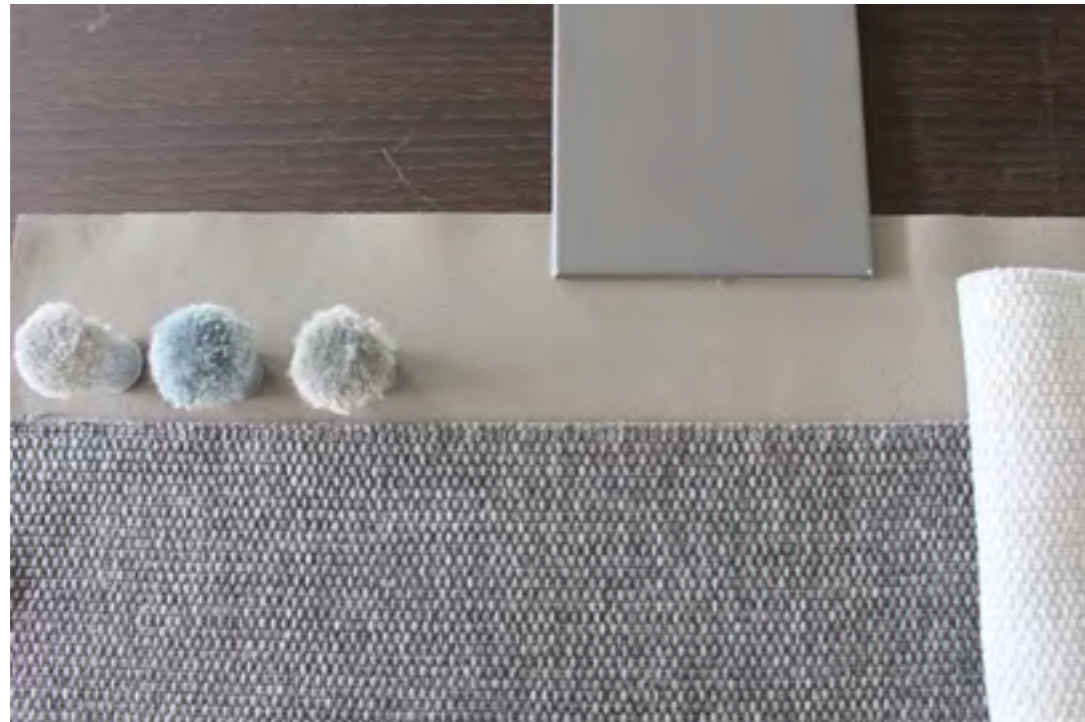

MisuraEmme  
CONTRACT

BEDROOM 2 STONE POUF(15)



MisuraEmme  
CONTRACT

BEDROOM 2 GHIROLETTO BED(14) (king size)

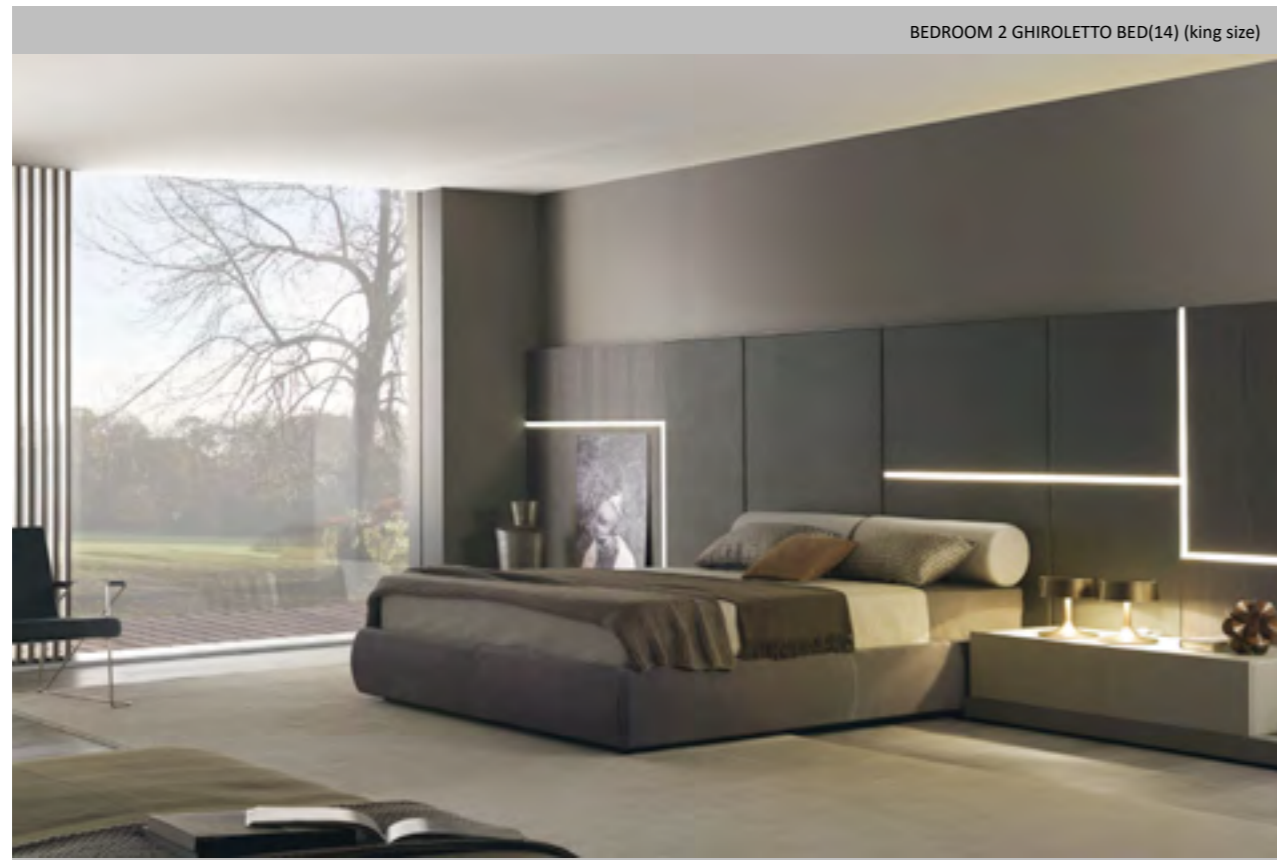

MisuraEmme  
CONTRACT

BEDROOM 2 GHIROLETTO BED (king size)

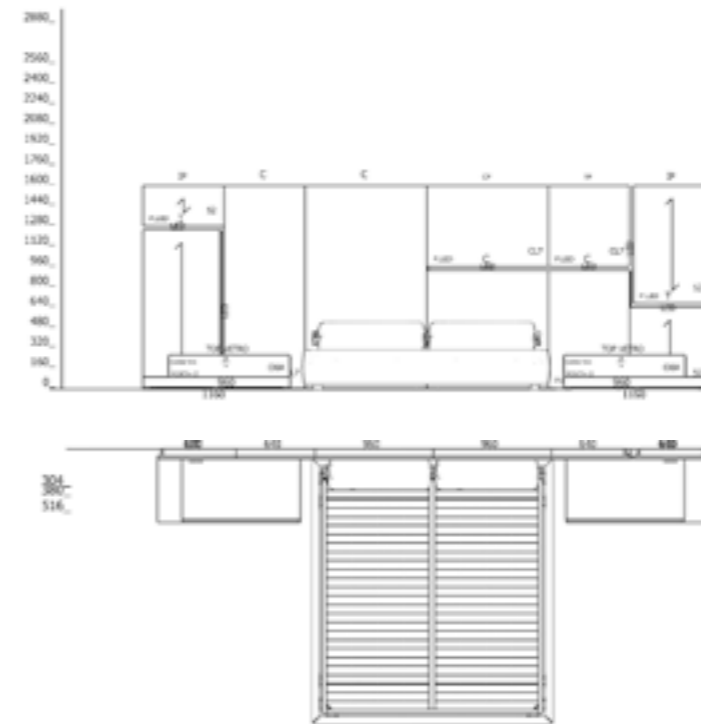

MisuraEmme  
CONTRACT

MOODBOARD

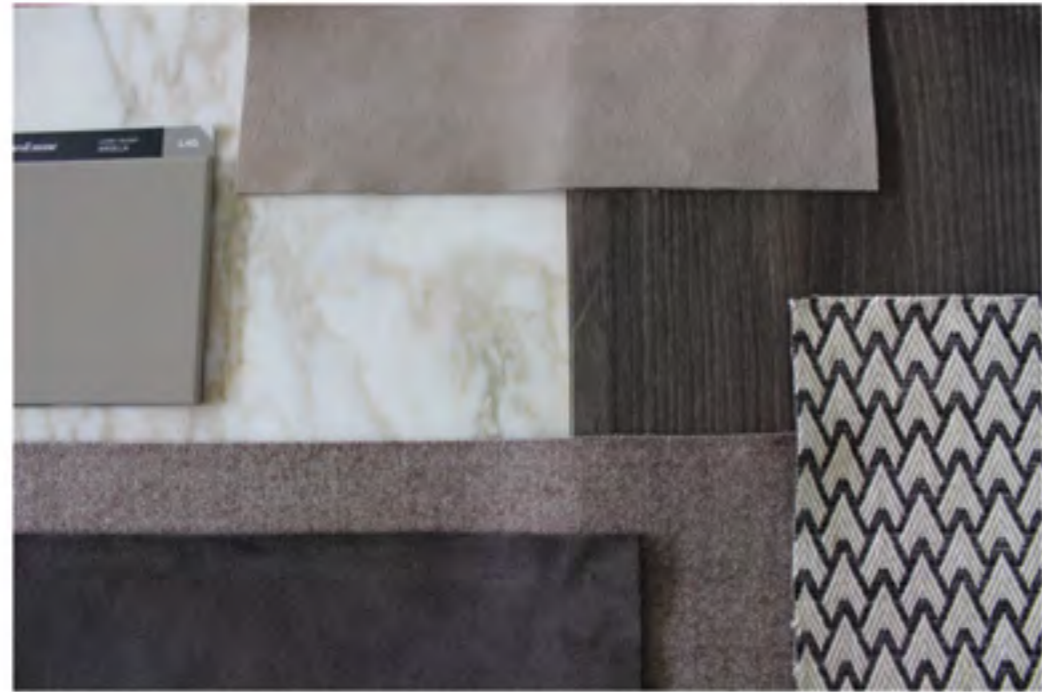

MisuraEmme  
CONTRACT

BEDROOM 1 JANUS COFFEE TABLE (21)ARMCHAIR SURFACE(22)



MisuraEmme  
CONTRACT

BEDROOM 2 PALO ALTO WALK IN CLOSET(18)



MisuraEmme  
CONTRACT

BEDROOM 2 PALO ALTO WALK IN CLOSET

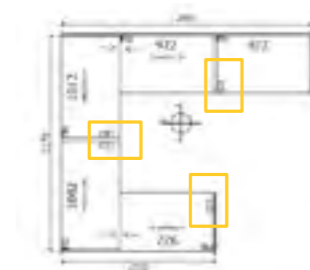
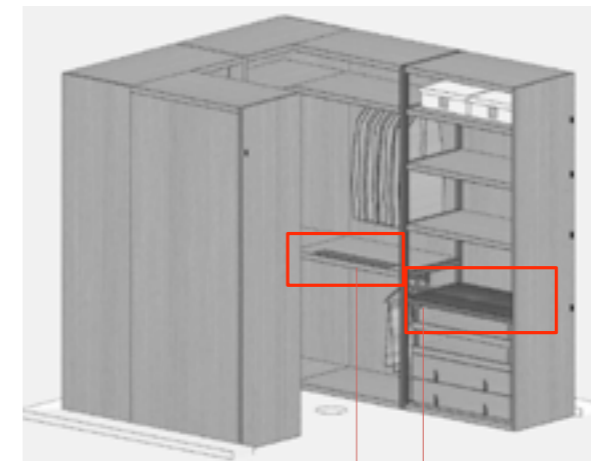

TOP IN ECCOLEATHER

VALET TRAY IN GUN METAL

N.2 EXTRACTABLE SHOE RACK TRAY

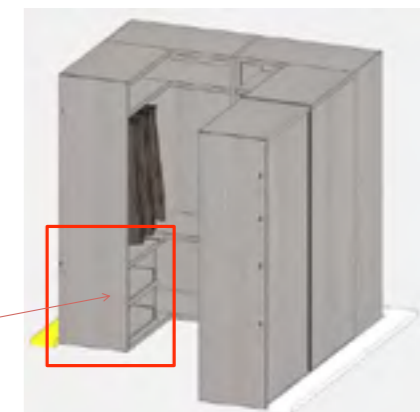

MisuraEmme  
CONTRACT

MOODBOARD

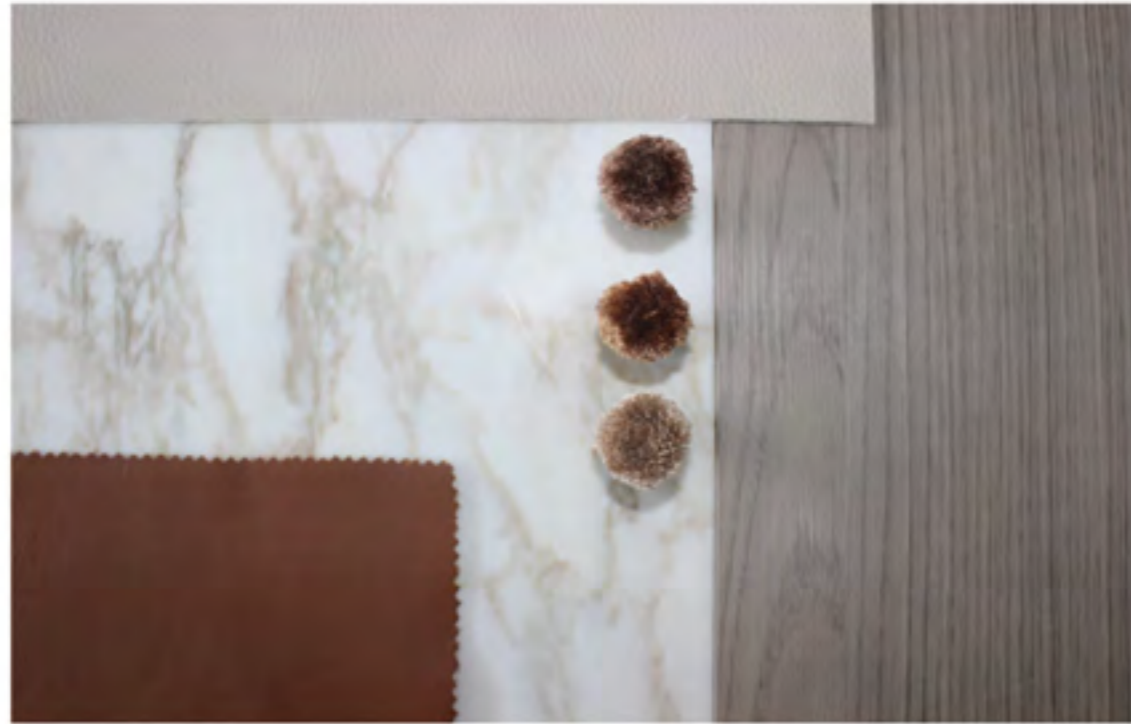

MisuraEmme  
CONTRACT

BEDROOM 1 LONDON WARDROBE



MisuraEmme  
CONTRACT

BEDROOM 1 MARGARETH BED(19) (king size)



MisuraEmme  
CONTRACT

BEDROOM 1 LONDON WARDROBE

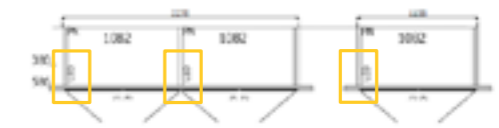
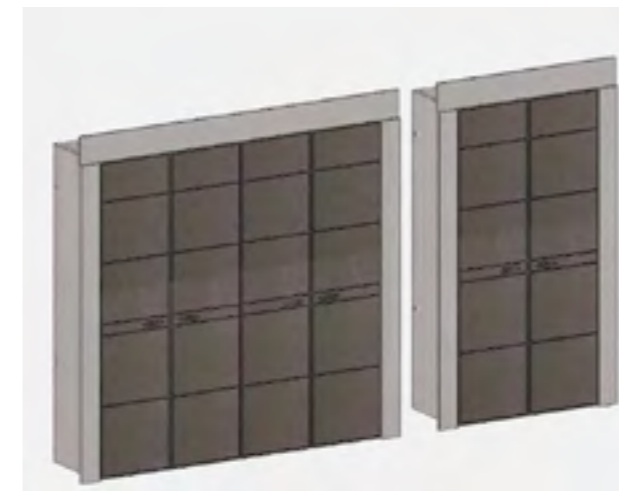

MisuraEmme  
CONTRACT

BEDROOM 1 VANITY ELEMENT(25)



MisuraEmme  
CONTRACT

BEDROOM 1 VANITY ELEMENT

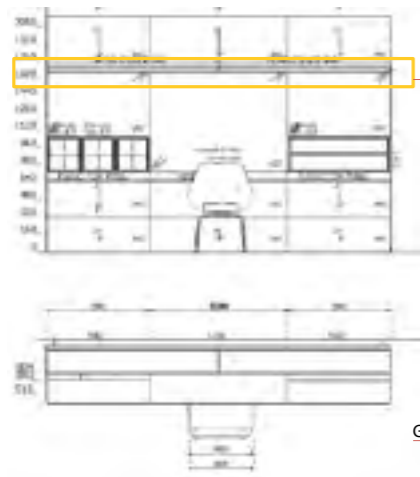

STRIP LED

GLASS



MisuraEmme  
CONTRACT



**MisuraEmme® S.p.A.**  
Via IV Novembre, 72  
22066 Mariano Comense (CO)  
Tel. +39 031.754111  
Fax. +39 031.744437  
info@misuraemme.it  
[www.misuraemme.it](http://www.misuraemme.it)